

3		2			
PART REV	DWG ISSUE	DATE	ECN NO.	APPVD BY	REL BY
-	-				

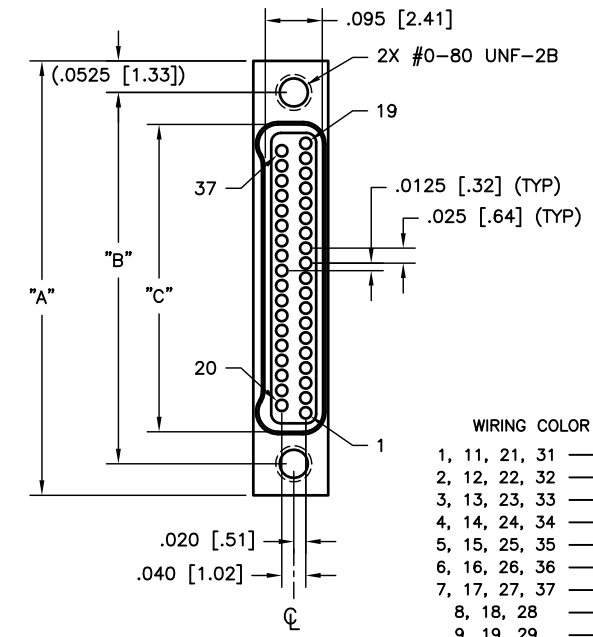

WIRING COLOR CODE

1, 11, 21, 31	—	BLACK
2, 12, 22, 32	—	BROWN
3, 13, 23, 33	—	RED
4, 14, 24, 34	—	ORANGE
5, 15, 25, 35	—	YELLOW
6, 16, 26, 36	—	GREEN
7, 17, 27, 37	—	BLUE
8, 18, 28	—	VIOLET
9, 19, 29	—	GRAY
10, 20, 30	—	WHITE

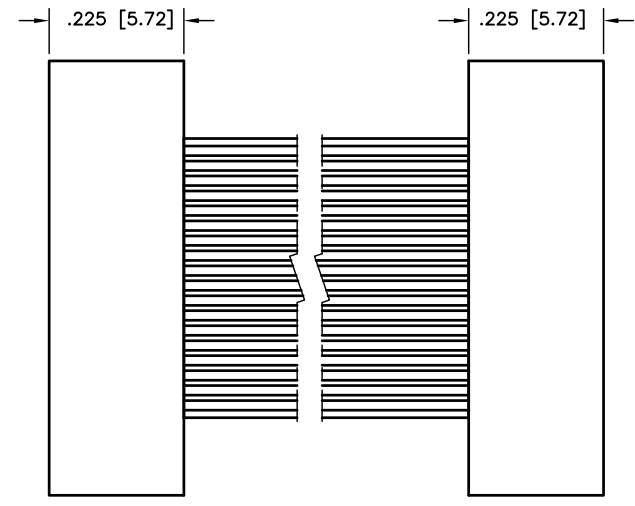
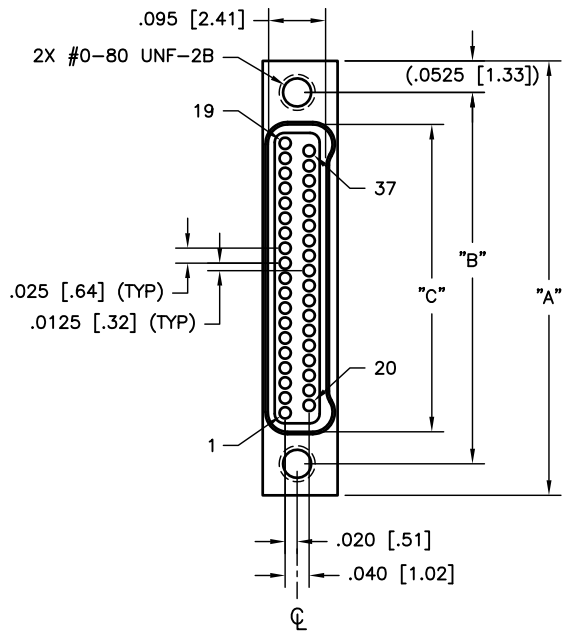

PART NO.	SIZE	"A"	"B"	"C"
833911627	9	.375 [9.52]	.270 [6.86]	.163 [4.14]
833921627	15	.450 [11.43]	.345 [8.76]	.238 [6.04]
833931627	21	.525 [13.33]	.420 [10.67]	.313 [7.95]
833941627	25	.575 [14.60]	.470 [11.94]	.363 [9.22]
833951627	31	.650 [16.51]	.545 [13.84]	.438 [11.12]
833961627	37	.725 [18.41]	.620 [15.75]	.513 [13.03]
833971627	51	.900 [22.86]	.795 [20.19]	.688 [17.47]
833981627	65	1.075 [27.30]	.970 [24.64]	.863 [21.92]

3. PERFORMANCE: MEETS OR EXCEEDS M32139 PERFORMANCE SPECIFICATIONS
 CONTACT RATING: 1 AMPERE MAXIMUM
 INSULATION RESISTANCE: 5000 MEGOHMS MINIMUM @ 100 VDC
 CONTACT RESISTANCE: 0.071 VOLT MAXIMUM DROP @ 1.0 AMPS (.071 OHMS) W/6.00" OF WIRE LISTED BELOW, PER MIL-DTL-32139

2. MATERIALS: SHELL: ALUMINUM 6061-T6, ELECTROLESS NICKEL PLATED PER AMS-C-26074
 INSULATOR: LCP (LIQUID CRYSTAL POLYMER) GLCP-30F
 CONTACT: BRASS ALLOY 735, GOLD PLATED PER ASTM B488
 LEADS: 30 AWG, NEMA HP3, TYPE ET, COLOR CODED PER MIL-DTL-681, SYSTEM 1, EXCEPT USING 10 SOLID REPEATING COLORS, 18.0" +0.5/-0 LONG
 HARDWARE: 303 STAINLESS PER ASTM 582

1. MARKINGS: UMI, DATE CODE, UMI P/N AS SPACE PERMITS

NOTES: UNLESS OTHERWISE SPECIFIED

QUALITY SYMBOLS MAJOR = CRITICAL = SPC =	UNLESS SPECIFIED: ALL DIMENSIONS IN INCHES GENERAL TOLERANCES: 3 PLACE ±.005 2 PLACE ±.010 ANGULAR ±2°	SCALE 5:1	DWG SIZE B	THIRD ANGLE PROJECTION	REVISE ON CAD ONLY	
	DRAWN BY & DATE UMI 03-09-10	CHECKED BY & DATE	TITLE: NANO-D DUAL ROW CONNECTOR, MALE/FEMALE, SIZE XX, NMLXX-2S07/NMLXX-2S07-30F6-18.0-S01			
	APPROVED BY & DATE	CAD FILENAME SD-833961627.DWG	PART NO. SEE "TAB BLOCK"	DRAWING NO. SD-833961627	SHEET NO. 1 OF 1	
	Ulti-Mate CAGE CODE 58967	THIS DRAWING CONTAINS INFORMATION THAT IS PROPRIETARY TO ULTI-MATE INCORPORATED AND SHOULD NOT BE USED WITHOUT WRITTEN PERMISSION.				